

FyreWrap® Elite™ 1.5 Duct Insulation – Grease Duct Single-Layer System

Introduction

Unifrax's FyreWrap® Elite™ 1.5 Duct Insulation is a single-layer flexible enclosure for 1- and 2-hour fire-rated commercial kitchen grease ducts and hazardous exhaust ducts including chemical fume ducts. This slim, compact design offers the lightest system available and results in significant weight, space and labor savings when compared to traditional fire-rated shafts or competitive wrap systems. The system was tested per UL 1978 and complies with pre-2006 editions of the International Mechanical Code (IMC). FyreWrap Elite 1.5 provides the following features:

- Zero clearance to combustibles at all locations on wrap
- 1- and 2-hour fire endurance rating
- Alternate to fire-rated shaft enclosure
- Saves weight, space, labor
- Thinnest, lightest system available
- High-temperature, biosoluble insulation
- GREENGUARD listed for Microbial Resistance

Product Components

Core Material: FyreWrap Elite 1.5 incorporates Insulfrax® Thermal Insulation as its core material. Insulfrax is a high-temperature insulation made from a calcia, magnesia, silica chemistry designed to enhance biosolubility. It provides excellent insulation in a noncombustible blanket product form.

Encapsulating Material: The core insulation blanket is completely encapsulated in an aluminum foil fiberglass reinforced scrim covering. This scrim provides additional

Typical System Properties

Intertek Laboratories (OPL) Listed

California State Fire Marshal Listing

UL 1978 Internal Grease Duct Test (June 2002)

ASTM E-119 Full Scale Engulfment Test

ASTM E-814 Through-Penetration Firestop Test

ASTM E-84/UL 723

Flame Spread Rating:

Smoke Developed Rating:

ASTM E-136 Non-combustibility Test

ASTM C-518 Durability Test

ASTM C-518 Thermal Resistance

ASTM D-6329-03 Microbial Resistance

ASTM C-411 Hot Surface Performance

File 14870, Design Nos. UNI/FRD 120-09, UNI/FRD 120-10, UNI/FRD 120-16, UNI/FRD 120-11, Large Duct Size: 52" x 52" (UL1978), 70" x 70" (ASTM E-814)

No: 2440-1478:100

Zero Clearance to Combustibles at All Locations on Wrap

2-hour Fire Endurance Rating

F-Rating = 2 hrs.; T-Rating = 2 hrs

Unfaced Blanket	Encapsulated
-----------------	--------------

Zero	<25
------	-----

Zero	<50
------	-----

Passes

Passes

R value = 6.19 (4.13 per inch)

Resistant to Mold Growth

Passes

Complies with : NFPA 96 (up through 2001 Edition), 90A, 90B, 101; 2000 and 2003 International Mechanical Code (IMC), 2000 and 2003 International Building Codes (IBC), BOCA National Building Code/1999, 1999 Standard Building Code, 1997 Standard Mechanical Code, and 1997 Uniform Building Code (UBC).



FyreWrap® Elite™ 1.5 Duct Insulation

handling strength as well as protection from grease and moisture absorption and tearing.

Typical Product Parameters

Thickness	1.5"
Nominal Density	6pcf
Standard Product Form	Scrim Encapsulated
Product Availability	24"w x 25LF 48"w x 25LF



Complies with:



2001 Edition



Listed



Member

International Firestop Council

Installation

The FyreWrap Elite 1.5 Duct Insulation consists of a single-layer system applied directly on to the duct surface. Only encapsulated blanket should be utilized to ensure the outer surface of the insulation is protected. The insulation system may be installed at zero clearance to combustibles at all locations on the wrap, at material overlaps, and in the field between overlaps. Install insulation with a 3" minimum overlap on all joints. Seal all cut edges with aluminum foil tape. The transverse overlap of adjacent blanket may be installed using the following three techniques. See Figure 1 for details.

Telescoping Overlap Wrap Technique:

This wrap technique is the most common method of installing FyreWrap Elite 1.5 where each adjacent blanket has one edge exposed and one edge covered by the next blanket.

Checkerboard Overlap Wrap Technique:

This installation uses a 3" overlap pattern with both edges of each alternating blanket covered by each adjacent blanket whose edges are exposed. The overlap joints in alternate layers of blanket resemble a checkerboard pattern in the completed installation. This technique is often utilized when a small section of duct wrap must be repaired.

Butt Splice with Collar Wrap Technique:

This wrap technique permits installation with the blanket edges butted together and a 6" wide collar of blanket that is centered over the butt splice, overlapping each adjacent blanket 3". The collar can be field fabricated from FyreWrap Elite 1.5 rolls or purchased separately.

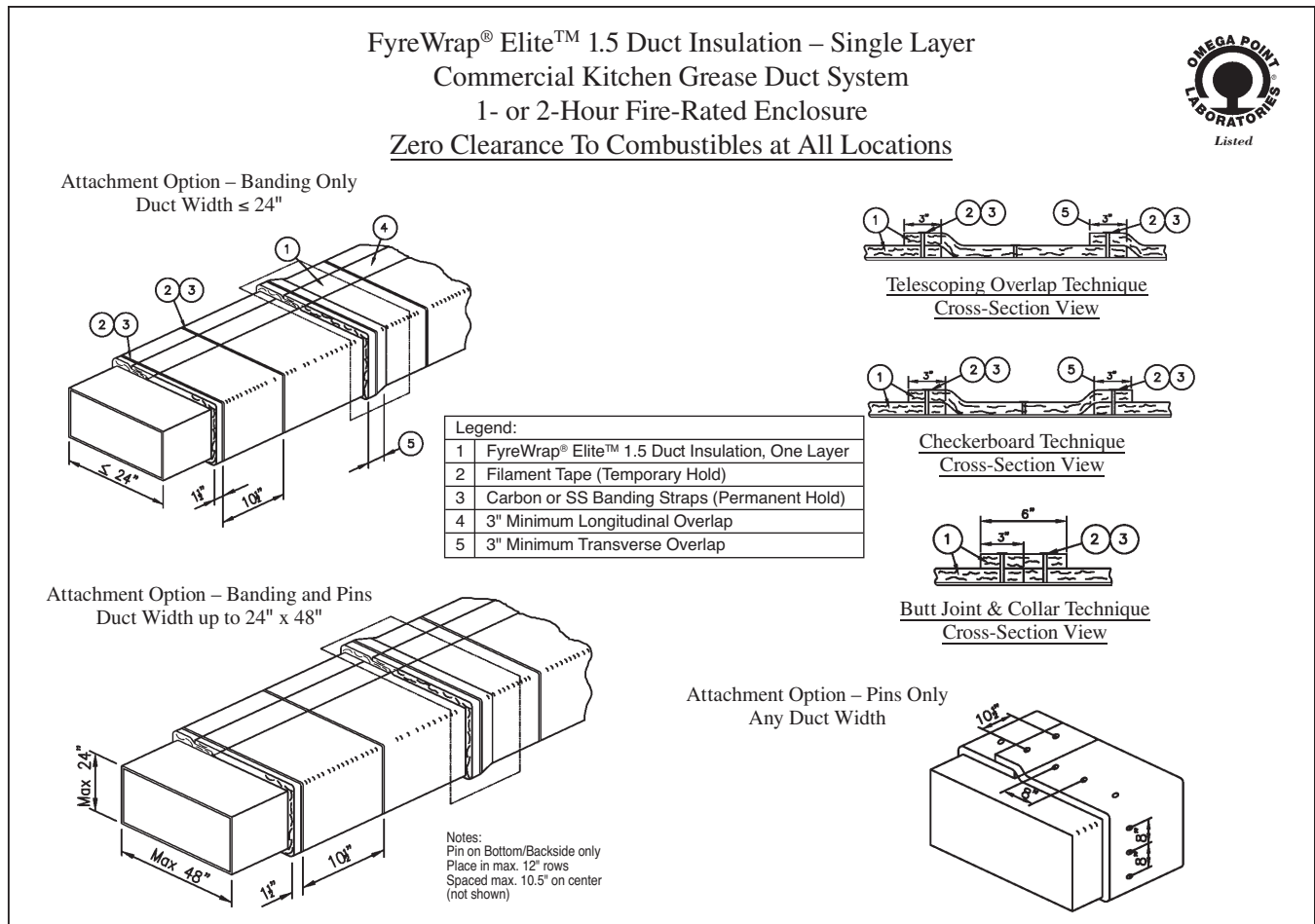

Figure 1. FyreWrap Elite™ 1.5 Single-Layer Installation Techniques

Butt Splice with Pins Wrap Technique:

This wrap technique permits the blanket to be installed with 2" compression joints at all material seams and no material overlaps. This technique is allowed only when pins are used on all sides of the duct to attach the blanket. Pins shall be spaced in 8" rows and on 8" centers. The compression joint is made by overlapping the blanket a minimum two inches. The ends of the blanket are then raised to align the edges, then pushed down together so the ends of the two pieces are under compression and butted together. See Figure 2 for additional details.

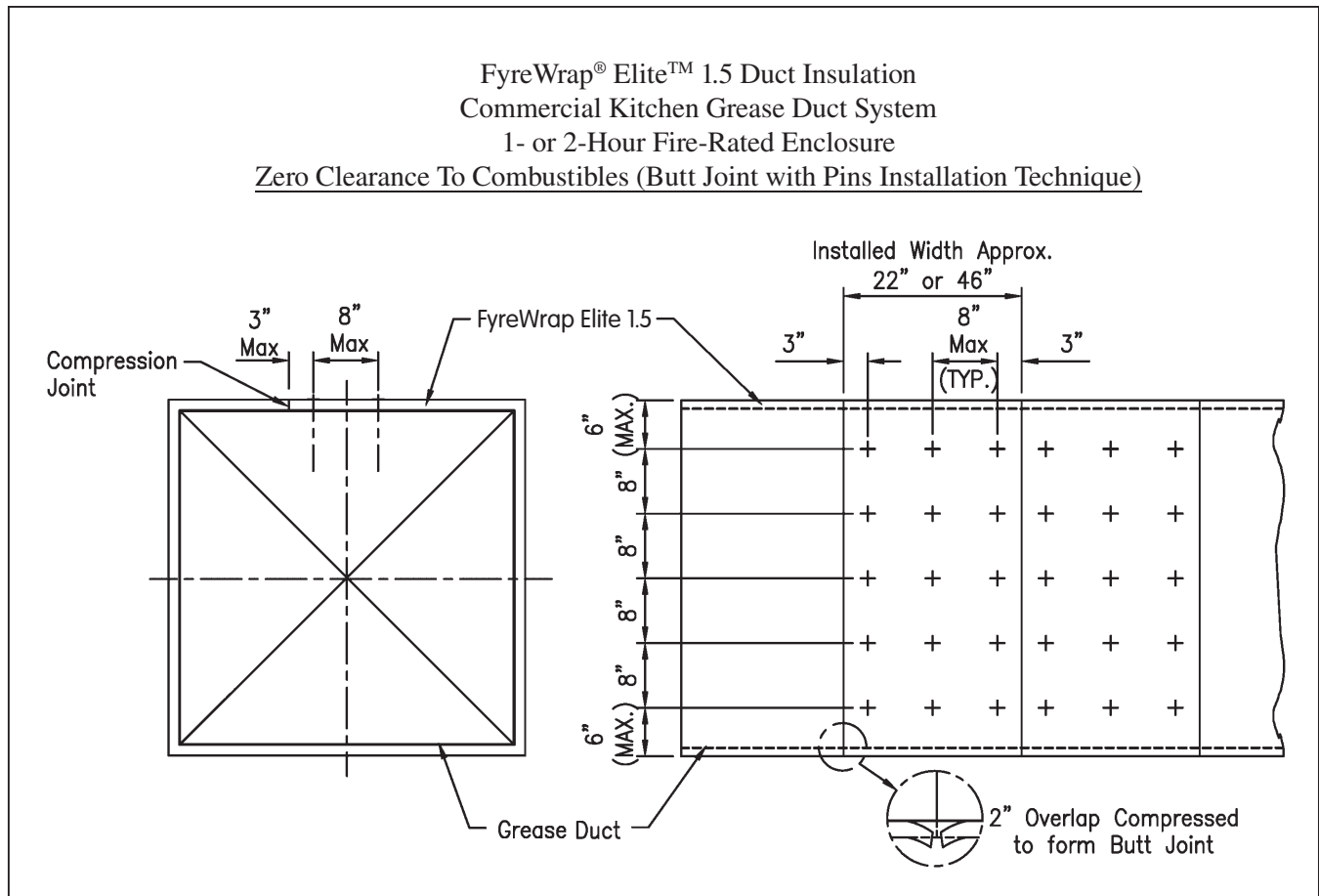

Figure 2. FyreWrap Elite™ 1.5 Butt Splice with Pins Wrap Technique

Vertical Duct Runs

For vertical duct runs, insulation may be applied to the duct in a continuous length parallel to the vertical length of the duct as opposed to wrapping around the duct. All overlaps shall be maintained at a minimum 3" and are to occur a minimum 6" from any corner of the duct. Pins spaced a maximum 8" on center are to be placed at the centerline of all vertically oriented overlaps. Pins may be pre-welded or cup head style pins. See Figure 3 for details.

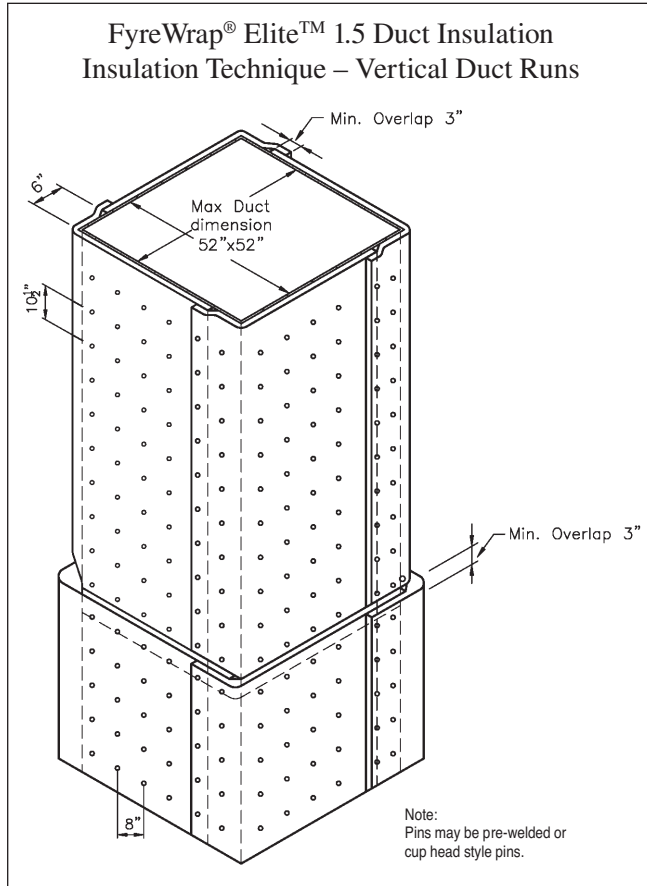

Figure 3. Optional Installation Technique – Vertical Duct Runs

Attachment Options

Three attachment options are available for installers. Choices are limited by the duct width dimension. Details on each option are provided below.

Banding Only: For Duct Widths 24" or Less

To temporarily secure the insulation, optional use of filament tape is permitted. Place carbon steel or stainless steel bands (min. 1/2" wide, nom. 0.015" thick) over joints and within the field around the wrap. Locate bands 1 1/2" from each edge of the blanket, centered on the overlap, and on 10 1/2" centers. Tighten banding to firmly hold the wrap system in place but not so tight as to cut or damage the blanket. Pins are NOT required when this banding technique is used.

Banding and Pins: For Duct Widths Up to 24" x 48"

Weld 12-gauge steel insulation pins to the underside of horizontal runs and backside (side of duct having largest dimension) of vertical runs. Place pins at maximum 12" rows and on maximum 10 1/2" centers. To temporarily secure the insulation, optional use of filament tape is permitted. Impale FyreWrap Elite 1.5 over the pins and hold in place with 2 1/2" square galvanized steel speed clips (washers). Turn down or cut off exposed ends of pins to eliminate safety hazards. Locate carbon steel or stainless steel bands (min. 1/2" wide, nom. 0.015" thick) 1 1/2" from each edge of the blanket, centered on the overlap, and on 10 1/2" centers. Tighten banding to firmly hold the wrap system in place but not so tight as to cut or damage the blanket. Cup head style pins are also permitted and shall be located at the same spacing as pre-welded pins.

Pins Only: For Any Duct Width

Weld 12-gauge steel insulation pins on all sides of the duct. Place insulation pins in rows (perpendicular to the length of the duct) spaced maximum 10 1/2" on center. Pins in each row are maximum 6" from each duct edge and maximum 8" on center. Locate insulation overlaps so they are centered on the pins. Impale FyreWrap Elite 1.5 over the pins and hold in place with 2 1/2" square galvanized steel speed clips (washers) to keep the system from sagging. Turn down or cut off exposed ends of pins to eliminate safety hazards. Cup head style pins are also permitted and shall be located at the same spacing as pre-welded pins.

Attachment Options (Summary Chart):

Duct Dimension	Banding Only	Banding & Pins (Pins on Bottom)	Pins Only (All Four Sides)
Width ≤ 24"	•	•	•
Width Up To 48"		•	•
Width > 48"			•

Access Door

Field fabricated and prefabricated grease duct access doors are permitted for use with FyreWrap Elite 1.5 Duct Insulation. Installation details are provided below and in Figure 4.

Field fabricated-access doors are protected with two layers of FyreWrap Elite 1.5 Duct Insulation. Cut away the one layer of FyreWrap Elite 1.5 already installed and covering the duct to a dimension that matches the door opening to be used. Mark and cut a clean-out access opening in the duct. Weld $\frac{1}{4}$ inch diameter threaded rod to each corner on the access door opening. Cover with hollow steel tubes (optional) for easy removal of blanket. Cut a 16 gauge cover plate with dimensions two inches larger than the opening. Drill holes in the door to match the rod pattern. Use a gasket of 0.5" thick unfaced FyreWrap or ceramic fiber blanket between the duct and the access door cover. Install the cover over the threaded rod overlapping the opening 1" on all sides. Weld at least four steel insulation pins to the outside of the door cover panel, approximately 1" from each corner. Cut a piece of FyreWrap Elite 1.5 that matches the door opening size and install over pins to fit within the insulation area cut away. Cut an additional piece of FyreWrap Elite 1.5 with perimeter dimensions that extend 1" beyond the layer below. Install over the insulation pins. Throughout the installation process, seal all cut edges with aluminum foil tape. Secure with washers and bend over excess pin lengths to eliminate safety hazards. Place washers on threaded rod and secure with nuts. Do not install banding over this area.

Prefabricated – Ductmate Ultimate and Ductmate F2-HT prefabricated access doors are permitted and must be installed in accordance with Ductmate Industries, Inc. installation instructions and the applicable code. The first layer of FyreWrap Elite 1.5 is cut to the size of the door. An additional layer is required and is sized to create an overlap of 1" beyond the lower layer. All edges of insulation blanket must be protected with aluminum foil tape. A No. 16 gauge outer plate the same dimension as the outer layer of insulation blanket is held in place over the insulation using threaded rod and wing nuts. The outer plate is supplied with the Ultimate door and F2-HT door. Access doors are available from Ductmate Industries, Inc. Contact www.ductmate.com or 1-800-245-3188 for additional information or local distributors. Ask for the Access Door Product Line manager.

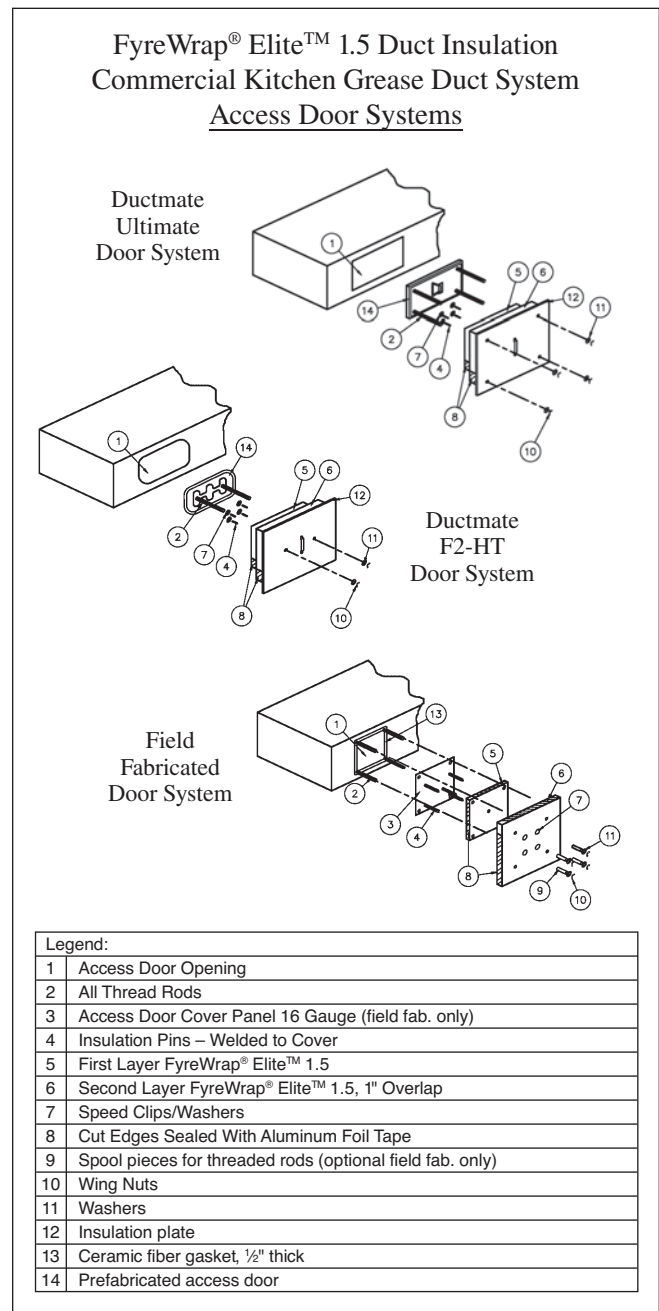

Figure 4. Access Door Installation

Duct Support

Horizontal duct support systems are not required to be insulated (wrapped) when constructed using a minimum $\frac{3}{8}$ " diameter uninsulated all-thread steel rod and $1\frac{1}{2}$ " x $1\frac{1}{2}$ " x $\frac{1}{4}$ " uninsulated steel angle spaced a maximum 120" on center along the length of the duct. A minimum clearance of 3" is required between the protected duct and the steel rod. For all other duct support configurations, a single layer of FyreWrap Elite 1.5 Duct Insulation is required on all components. Utilize a minimum 3" overlap (approximately a $\frac{1}{4}$ " turn) on all joints.

Firestop Systems

Refer to Figures 5, 6 and 7 for details. Contact Unifrax Application Engineering Group at 716-278-3888 or visit www.unifrax.com for the latest information on available firestop systems.

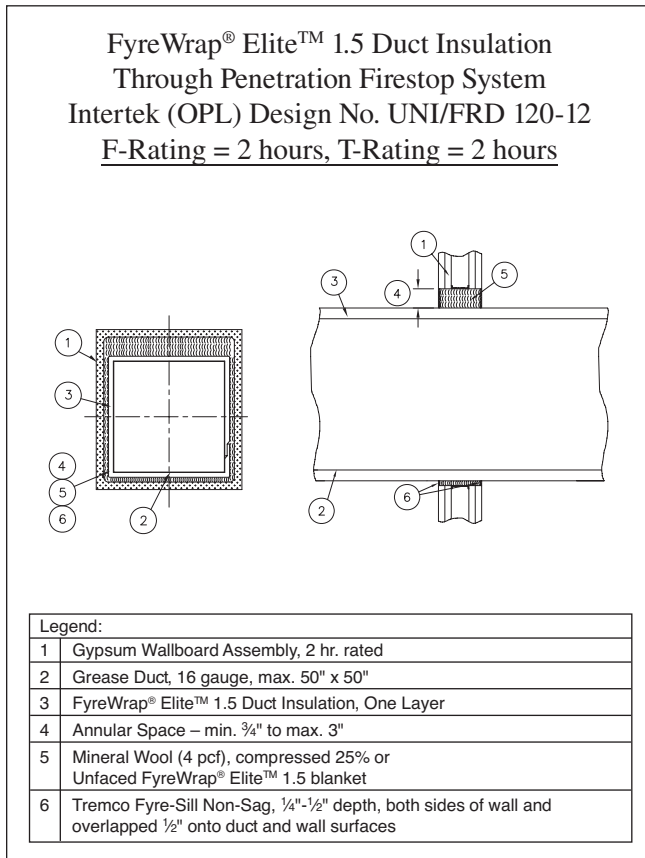

Figure 5. Firestop Installation

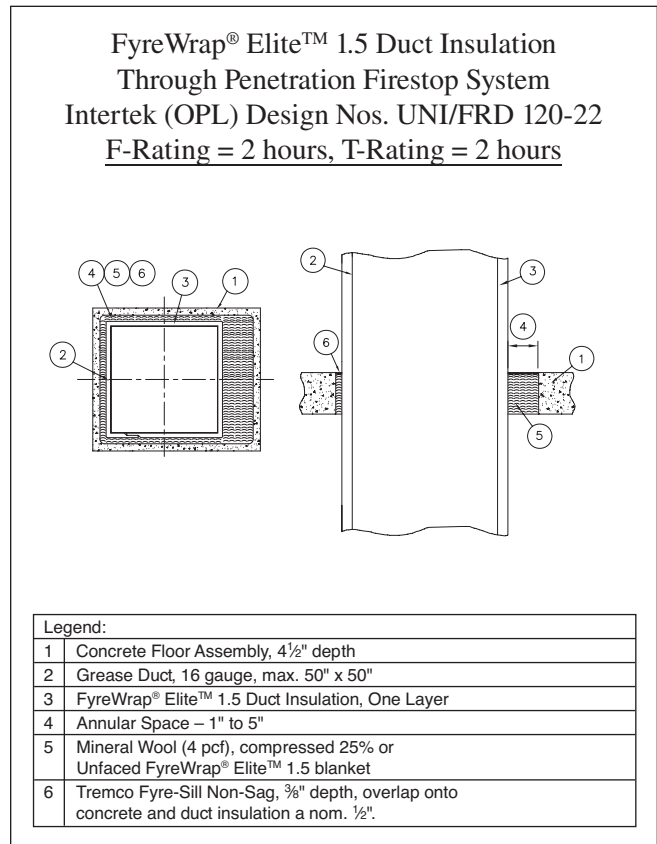
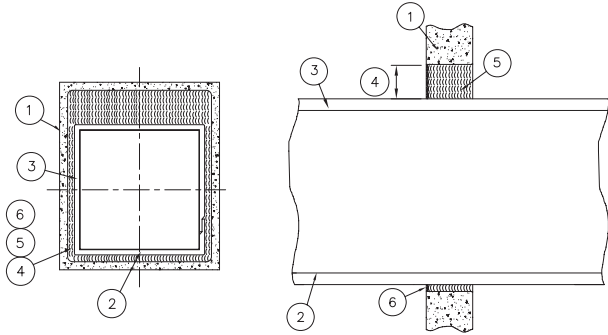

Figure 6. Firestop Installation

FyreWrap® Elite™ 1.5 Duct Insulation
Through Penetration Firestop System
Intertek (OPL) Design No. UNI/FRD 120-13
F-Rating = 2 hours, T-Rating = 2 hours



Legend:	
1	Concrete or CMU block wall assembly, 5 1/2"
2	Grease Duct, 16 gauge, max. 50" x 50"
3	FyreWrap® Elite™ 1.5 Duct Insulation, One Layer
4	Annular Space – 3/4" to 3"
5	Mineral Wool (4 pcf), compressed 25% or Unfaced FyreWrap® Elite™ 1.5 blanket
6	Tremco Fyre-Sill Non-Sag, 3/8" depth, overlap onto wall surface and duct insulation a nom. 1/2".

Figure 7. Firestop Installation

FyreWrap® Elite™ 1.5 Duct Insulation
Through Penetration Firestop System
Intertek (OPL) Design No. UNI/FRD 120-18
F-Rating = 2 hours, T-Rating = 2 hours

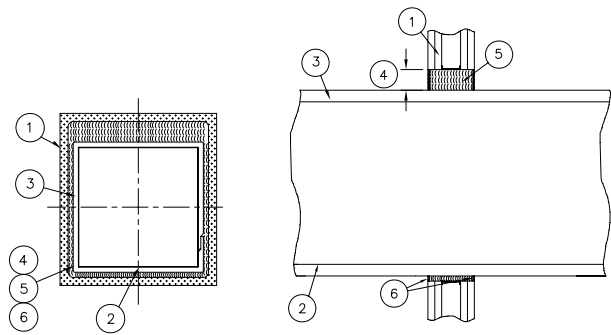

Legend:	
1	Gypsum Wallboard Assembly, 2 hr. rated
2	Grease Duct, 16 gauge, max. 70" x 70"
3	FyreWrap® Elite™ 1.5 Duct Insulation, One Layer
4	Annular Space – 1 1/4" to max. 4 3/4"
5	Unfaced FyreWrap® Elite™ 1.5 blanket compressed 48%.
6	Specified Technologies spec seal SSS100 intumescent firestop sealant, 5/8" nominal depth, both sides of wall and overlapped 1/2" onto duct and wall surfaces.

Figure 8. Firestop Installation

FyreWrap® Elite™ 1.5 Duct Insulation
Through Penetration Firestop System
Intertek Design No. UNI/FRD 120-20
F-Rating = 2 hours, T-Rating = 2 hours

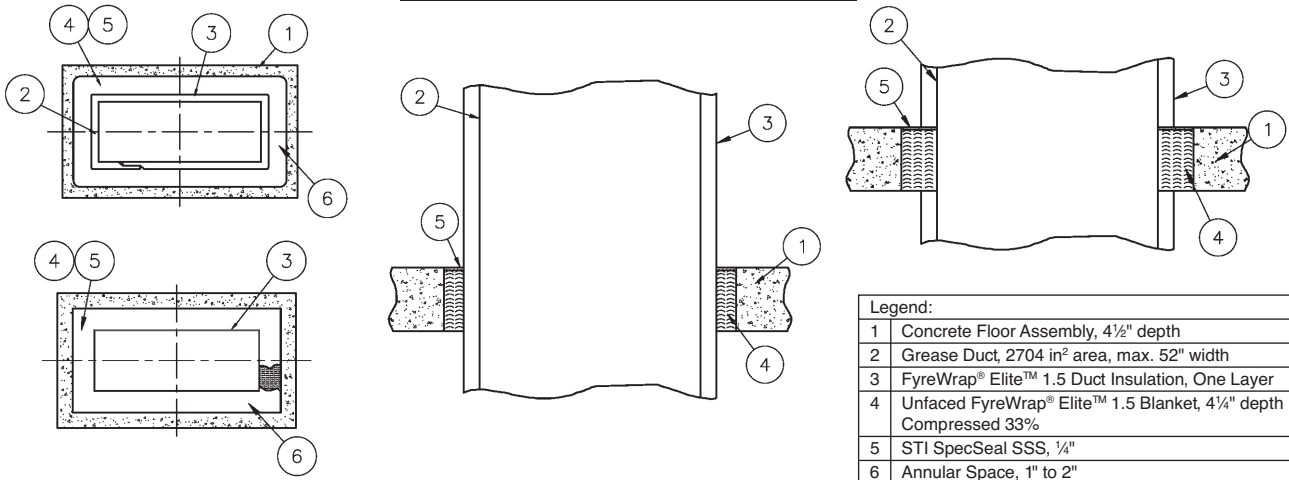

Legend:	
1	Concrete Floor Assembly, 4 1/2" depth
2	Grease Duct, 2704 in ² area, max. 52" width
3	FyreWrap® Elite™ 1.5 Duct Insulation, One Layer
4	Unfaced FyreWrap® Elite™ 1.5 Blanket, 4 1/4" depth Compressed 33%
5	STI SpecSeal SSS, 1/4"
6	Annular Space, 1" to 2"

Figure 9. Firestop Installation



Other Fire Protection Products and Applications

Unifrax offers many UL-listed Fiberfrax® and FyreWrap® product forms and FyreWrap fire protection materials for passive fire protection applications, such as:

Product	UL File Number
FyreWrap® Duct Insulation	R14514
Insulfrax® S Blanket	R14514
FyreWrap® XFP® – Expanding Fyre Paper	R15435
Fiberfrax® Durablanket® Ceramic Fiber Blanket	R14514
Fiberfrax® Duraboard® Ceramic Fiber Board LD	E75289
Fiberfrax® Ceramic Fiber Papers (110/440)	E75289
Fiberfrax® Ceramic Fiber Papers (970)	MH7030
Fiberfrax® Lo-Con™ Felt	MH7030
Fiberfrax® Moist Pak-D®	E75289

Unifrax has a wide range of FyreWrap fire protection materials available to provide passive fire protection solutions in a variety of applications in the commercial building, industrial facility and transportation industries.

For additional information about product performance or to identify the recommended product for your fire protection application, please contact the Unifrax Application Engineering Group at 716-278-3888.

FyreWrap products offer solutions in applications such as:

- Grease, HVAC Ducts
- Cable Trays, Conduit
- Control System Covers
- Above Ground Storage Tanks
- Marine Bulkheads, Decks
- Structural Steel
- Construction Joints
- Curtain Walls/Safing
- Circuit Protection
- Railroad Tank Cars
- Transit Cars
- Ships
- Expansion Joints
- Fire Door Seals
- Chimney Liners
- Ceiling Air Diffusers
- Hazardous Material Storage Containers



 <p>OMEGA POINT LABORATORIES US</p>	<p>APPLIED FIRE PROTECTION</p> <p>UNIFRAX I LLC New Carlisle, IN</p> <p>FyreWrap® Elite™ 1.5 Duct Insulation Nominal Density: 6 pcf</p>
	<p>Tested Per: ASTM E119 - Fire Resistance Rating: 2 hour ANSI/ASTM E814 - T-Rating: 2 hr F-Rating: 2 hour ASTM E2336 UL 1978 (June 2002) - Sec. 14 & 15 - Passed UL 2221 AC 101 (Engulfment) - Passed AC 101 (Internal) - Passed ISO 6944 - Duct Type: A</p>
<p>Listed W/N 14870 Reference Directory of Listed Building Products, Materials & Assemblies for Specifics</p>	

Data are average results of tests conducted under standard procedures and are subject to variation. Results should not be used for specification purposes.

Refer to the product Material Safety Data Sheet (MSDS) for recommended work practices and other product safety information.

Form C-1494
Effective 11/08
© 2008 Unifrax I LLC
All Rights Reserved
Printed in USA
Page 8 of 8

The following are registered trademarks of Unifrax: FyreWrap, Elite™, Insulfrax, XFP, Lo-Con, Moist Pak-D, Fiberfrax, Durablanket, and Duraboard. The test data shown are average results of tests conducted under standard procedures and are subject to variation. Results should not be used for specification purposes.

Product Information Sheets are periodically updated by Unifrax. Before relying on any data or other information in this Product Information Sheet, you should confirm that it is still current and has not been superseded. A Product Information Sheet that has been superseded may contain incorrect, obsolete and/or irrelevant data and other information.

FyreWrap®

Unifrax I LLC
Corporate Headquarters
2351 Whirlpool Street
Niagara Falls, New York 14305-2413
Telephone: 716-278-3800
Telefax: 716-278-3900
Internet: www.unifrax.com
Email: info@unifrax.com